

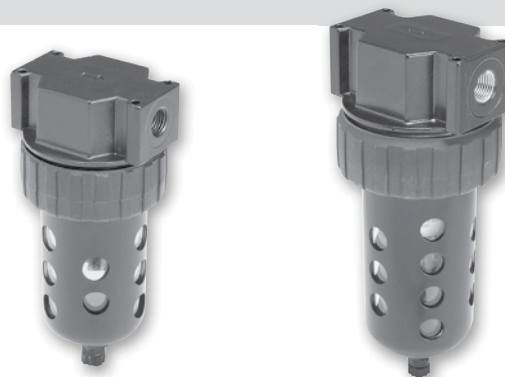

06F, 07F Prep-Air II Particulate Filters

- Excellent water removal efficiency
- Unique deflector plate and shroud creates a swirling of the air stream ensuring maximum water and dirt separation
- Large filter element surface guarantees low pressure drop and increased element life
- Optional automatic float drain available
- 06F: 1/4", 3/8" & 1/2" ports (NPT & BSPP)
- 07F: 1/2" & 3/4" ports (NPT & BSPP)



06F

07F

Material specifications

Body	Zinc
Bowls	Transparent polycarbonate or Metal (zinc) with or without sight gauge
Bowl guards	Steel
Collar	Plastic (06, 07) or metal (07)
Deflector, shroud & baffle	Plastic
Drain	Plastic
Automatic float drain –	
Housing, float	Plastic
Seals	Nitrile
Springs, push rod	Stainless steel
Filter elements –	
40 Micron (standard)	Plastic
5 Micron (optional)	Plastic
Seals	Nitrile
Sight gauge	Polyamide

Operating information

06F & 07F		
Operating pressure:	Poly bowl Metal bowl	0 to 150 PSIG (0 to 10.3 bar) 0 to 250 PSIG (0 to 17.2 bar)
Auto float drain:	Poly bowl Metal bowl	15 to 250 PSIG (1.0 to 17.2 bar)
Operating temperature:	Poly bowl Metal bowl	32°F to 125°F (0°C to 52°C) 32°F to 175°F (0°C to 80°C)

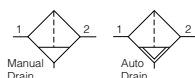

06F, 07F Particulate Filters

	Port size	Bowl type	Flow SCFM	Element type	Part number (NPT)	
					Twist drain	Automatic float drain
06F	1/4"	Poly bowl / Metal guard	53	40 micron	06F12AC	06F16AC
	1/4"	Metal bowl / Sight gauge	53	40 micron	06F14AC	06F18AC
	3/8"	Poly bowl / Metal guard	80	40 micron	06F22AC	06F26AC
	3/8"	Metal bowl / Sight gauge	80	40 micron	06F24AC	06F28AC
	1/2"	Poly bowl / Metal guard	85	40 micron	06F32AC	06F36AC
	1/2"	Metal bowl / Sight gauge	85	40 micron	06F34AC	06F38AC
07F	1/2"	Poly bowl / Metal guard	75	40 micron	07F32AC	07F36AC
	1/2"	Metal bowl / Sight gauge	75	40 micron	07F34AC	07F38AC
	3/4"	Poly bowl / Metal guard	80	40 micron	07F42AC	07F46AC
	3/4"	Metal bowl / Sight gauge	80	40 micron	07F44AC	07F48AC

Most popular.



06F (Compact)

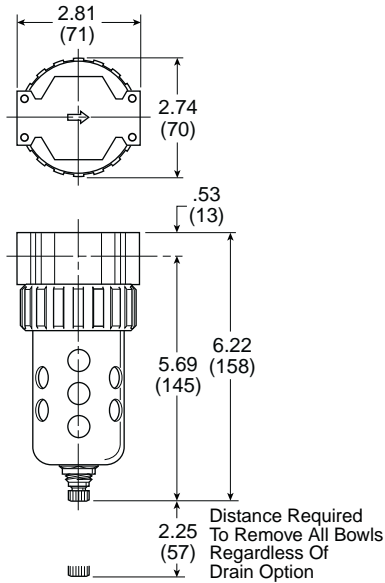

07F (Standard)

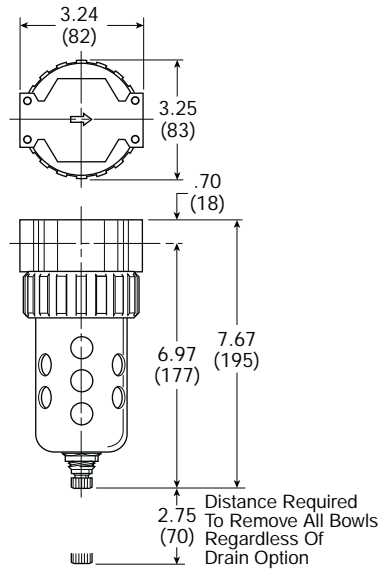

Service kits

Description	06F (Compact)	07F (Standard)
Bowl guard kit	PS705P	PS805P
Bowl Kits –		
Poly bowl –		
Auto float drain	PS722P	PS822P
Twist drain	PS732P	PS832P
Metal bowl –		
Auto float drain	PS726P	PS826P
Twist drain	PS734P	PS834P
Sight gauge / automatic float drain	PS723P	PS823P
Sight gauge / twist drain	PS735P	PS835P
DPI replacement kit	PS781P	PS781P
Drain kits –		
Auto float drain	PS506P	PS506P
Semi-auto drain	PS511P	PS511P
Twist drain	PS512P	PS512P
Push 'N' Drain	PS513P	PS513P
Filter element kit –		
40 micron	PS701P	PS801P
5 micron	PS702P	PS802P
Adsorber	PS731P	PS831P
Mounting bracket kit	PS743P	PS843P
Sight gauge kit	PS914P	PS914P

☐ Most popular.





Air Preparation Products

Global

Prep-Air II

Miniature

P3N

General Industrial

Stainless Steel

Precision / Proportional

Bulk Liquid Separators

11F, 12F Prep-Air II Coalescing Filters

- Removes liquid aerosols and sub-micron particles
- Liquids gravitate to the bottom of the element and will not re-enter the airstream
- Oil free air for critical applications, such as air gauging and pneumatic instrumentation and controls
- Interchangeable twist and automatic float drains
- Differential pressure indicator standard
- 11F: 1/4", 3/8" & 1/2" ports (NPT & BSPP)
- 12F: 1/2" & 3/4" ports (NPT & BSPP)



11F



12F

Material specifications

Body	Zinc
Bowls	Transparent polycarbonate or Metal (zinc) with or without sight gauge
Bowl guards	Steel
Collar	Plastic (06, 07) or metal (07)
Drain	Plastic
Automatic float drain –	
Housing, float	Plastic
Seals	Nitrile
Springs, push rod	Stainless steel
Filter element –	
Borosilicate & felt glass fibers 99.97% DOP efficiency	0.01 Micron
Largest Aerosol Particle Passed (Grade 6)	
Largest Solid Particle Passed (Grade 6)	0.30 Micron
Seals	Nitrile
Sight gauge	Polyamide

Operating information

11F & 12F		
Operating pressure:	Poly bowl Metal bowl	0 to 150 PSIG (0 to 10.3 bar) 0 to 250 PSIG (0 to 17.2 bar)
Auto float drain:	Poly bowl Metal bowl	15 to 250 PSIG (1.0 to 17.2 bar)
Operating temperature:	Poly bowl Metal bowl	32°F to 125°F (0°C to 52°C) 32°F to 175°F (0°C to 80°C)

Coalescing Filters

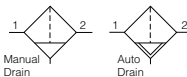

	Port size	Bowl type	Flow SCFM	Element type	Part number (NPT)	
					Twist drain	Automatic float drain
11F	1/4"	Poly bowl / Metal guard	45	0.01 micron	11F12EC	11F16EC
	1/4"	Metal bowl / Sight gauge	60	1.0 micron	11F14HC	11F18HC
	1/4"	Metal bowl / Sight gauge	45	0.01 micron	11F14EC	11F18EC
	1/4"	Metal bowl / Sight gauge	60	1.0 micron	11F14HC	11F18HC
	3/8"	Poly bowl / Metal guard	48	0.01 micron	11F22EC	11F26EC
	3/8"	Poly bowl / Metal guard	72	1.0 micron	11F22HC	11F26HC
	3/8"	Metal bowl / Sight gauge	48	0.01 micron	11F24EC	11F28EC
	3/8"	Metal bowl / Sight gauge	72	1.0 micron	11F24HC	11F28HC
	1/2"	Poly bowl / Metal guard	65	0.01 micron	11F32EC	11F36EC
	1/2"	Poly bowl / Metal guard	95	1.0 micron	11F32HC	11F36HC
12F	1/2"	Metal bowl / Sight gauge	65	0.01 micron	11F32EC	11F36EC
	1/2"	Metal bowl / Sight gauge	95	1.0 micron	11F34HC	11F38HC
	1/2"	Poly bowl / Metal guard	75	0.01 micron	12F32EC	12F36EC
	1/2"	Poly bowl / Metal guard	125	1.0 micron	12F32HC	12F36HC
	1/2"	Metal bowl / Sight gauge	75	0.01 micron	12F34EC	12F38EC
	1/2"	Metal bowl / Sight gauge	125	1.0 micron	12F34HC	12F38HC
	3/4"	Poly bowl / Metal guard	80	0.01 micron	12F42EC	12F46EC
	3/4"	Poly bowl / Metal guard	160	1.0 micron	12F42HC	12F46HC
	3/4"	Metal bowl / Sight gauge	80	0.01 micron	12F44EC	12F48EC
	3/4"	Metal bowl / Sight gauge	160	1.0 micron	12F44HC	12F48HC

Most popular.



11F (Compact)

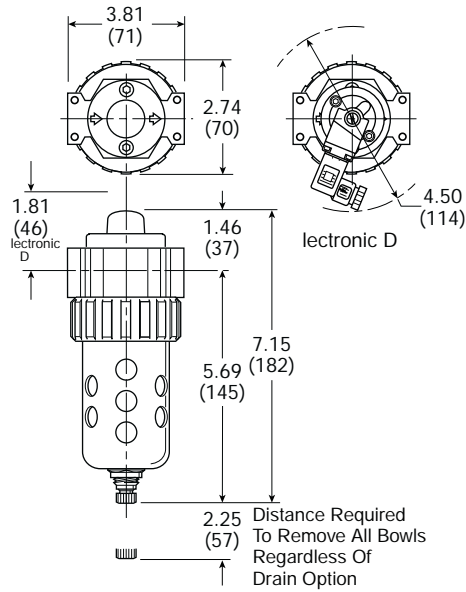

12F (Standard)

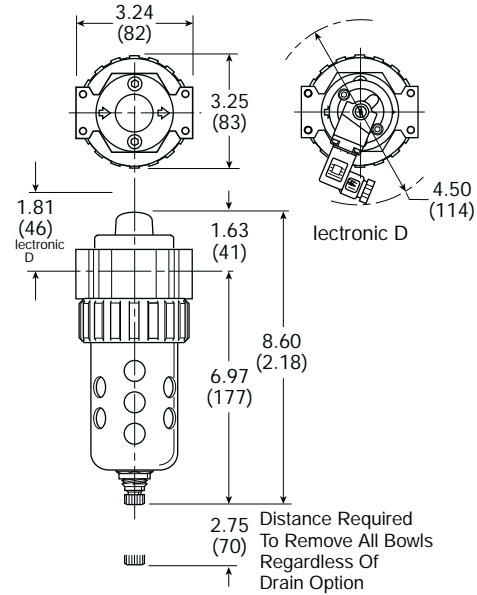

Service kits

Description	11F (Compact)	12F (Standard)
Bowl guard kit	PS705P	PS805P
Bowl Kits –		
Poly bowl –		
Auto float drain	PS722P	PS822P
Twist drain	PS732P	PS832P
Metal bowl –		
Auto float drain	PS726P	PS826P
Twist drain	PS734P	PS834P
Sight gauge / automatic float drain	PS723P	PS823P
Sight gauge / twist drain	PS735P	PS835P
DPI replacement kit	PS781P	PS781P
Drain kits –		
Auto float drain	PS506P	PS506P
Semi-auto drain	PS511P	PS511P
Twist drain	PS512P	PS512P
Push 'N' Drain	PS513P	PS513P
Electronic DPI replacement kit	PS764	PS764
Electrical connector - 15mm, 3-pin DIN, 6 Ft. Cord	PS2932JBP	PS2932JBP
Filter element kit –		
Grade 6 (Standard)	PS701P	PS824P
Grade 10 (Optional)	PS702P	PS830P
Mounting bracket kit	PS743P	PS843P
Sight gauge kit	PS914P	PS914P

Most popular.





Air Preparation Products

Global

Prep-Air II

Miniature

P3N

General Industrial

Stainless Steel

Precision / Proportional

Bulk Liquid Separators

06R, 07R Prep-Air II Regulators

- Secondary aspiration plus balanced poppet provides quick response and accurate pressure regulation
- Rolling diaphragm for extended life
- Two high flow 1/4" gauge ports can be used as additional outlets
- Easily serviced
- Removable non-rising knob for panel mounting and tamper resistance
- 06R: 1/4", 3/8" & 1/2" ports (NPT & BSPP)
- 07R: 1/2" & 3/4" ports (NPT & BSPP)

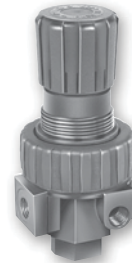

06R

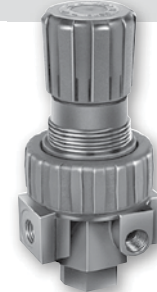

07R

Material specifications



Adjusting Stem	Steel
Body	Zinc
Bonnet, piston stem, valve poppet & cap	Plastic
Collar, knob	Plastic
Diaphragm	Nitrile
Seals	Nitrile
Springs – Poppet Control	Stainless Steel

Operating information

	06R (Compact), 07R (Standard)
Pressure rating:	250 PSIG (17.2 bar)
Temperature rating:	32°F to 175°F (0°C to 80°C)
Secondary pressure ranges –	
Standard pressure	2 to 125 PSIG (0 to 8.6 bar)
Medium pressure	1 to 60 PSIG (0 to 4.1 bar)
High pressure	5 to 250 PSIG (0.4 to 17.2 bar)



Regulators

	Port size	Pressure range	Flow SCFM	Part number (NPT)	
				Without gauge	With 160 PSI gauge
06R 	1/4"	125 PSIG	53	06R113AC	06R118AC
	3/8"	125 PSIG	60	06R213AC	06R218AC
	1/2"	125 PSIG	75	06R313AC	06R318AC
07R 	1/2"	125 PSIG	90	07R313AC	07R318AC
	3/4"	125 PSIG	90	07R413AC	07R418AC



WARNING

Product rupture can cause serious injury.
 Do not connect regulator to bottled gas.
 Do not exceed maximum primary pressure rating.

CAUTION: REGULATOR PRESSURE ADJUSTMENT –

The working range of knob adjustment is designed to permit outlet pressures within their full range. Pressure adjustment beyond this range is also possible because the knob is not a limiting device. This is a common characteristic of most industrial regulators, and limiting devices may be obtained only by special design. For best performance, regulated pressure should always be set by increasing the pressure up to the desired setting.

 Most popular.



06R (Compact)

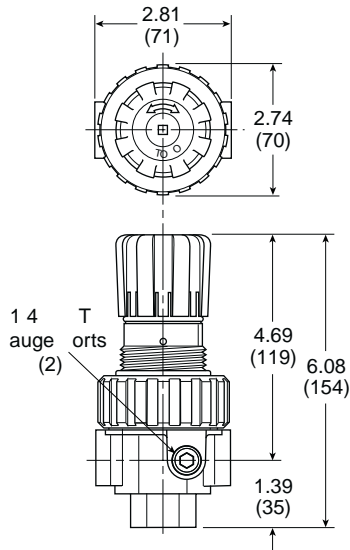

07R (Standard)

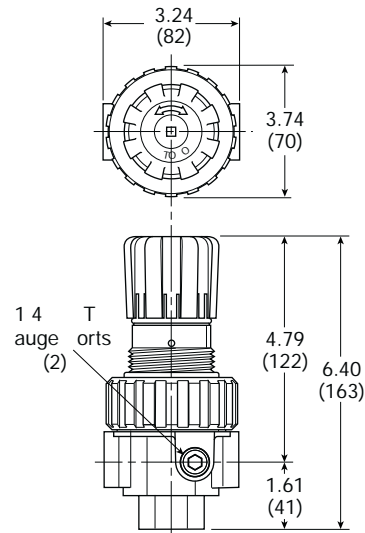

Service kits

Description		06R (Compact)	07R (Standard)
Bonnet assembly		PS715P	PS715P
Control knob		P04069B	P04069B
Gauges –	50mm (2") round 1/4" center back mount	60 PSIG (0 to 4.1 bar) K4520N14060	K4520N14060
		160 PSIG (0 to 11.0 bar) K4520N14160	K4520N14160
		300 PSIG (0 to 20.0 bar) K4520N14300	K4520N14300
	44mm (1-3/4") digital round 1/4" center back mount	0-160 PSIG / 0-11 bar / 0-1.1 MPa K4517N14160	K4517N14160
Mounting bracket kit (Includes panel mount nut)		PS707P	PS807P
Panel mount nut –	Plastic	P04082	P04079B
	Metal	P04082	P04079B
Reverse Flow Service Conversion Kit – Relieving		PS708RP	PS808RP
Springs –	1-30 PSIG range	P01698	P01698
	1-60 PSIG range	P04062	P04062
	2-125 PSIG range	P04063	P04063
	5-250 PSIG range	P04064	P04064
Tamperproof kit		PS737P	PS7373P

Most popular.





11R, 12R Prep-Air II Pilot Operated Regulators

- Balanced poppet provides quick response and accurate pressure regulation
- Pilot controlled regulators can be mounted “out of reach” with pilot regulator installed in a convenient location
- Solid control piston for extended life



11R



12R

Operating information

	11R	12R
Pressure rating:	0 to 250 PSIG (0 to 17.2 bar)	0 to 250 PSIG (0 to 17.2 bar)
Temperature rating:	32°F to 175°F (0°C to 80°C)	32°F to 175°F (0°C to 80°C)
Flow capacity SCFM:	1/4": 85 3/8": 95 1/2": 95	1/2": 140 3/4": 140

11R, 12R Pilot Controlled Regulators



Port size	Gauge	Part number (NPT), relieving	
		11R	12R
1/4"	No	11R115PC	
3/8"	No	11R215PC	
1/2"	No	11R315PC	12R315PB
3/4"	No		12R415PB
1/4"	160 PSI	11R121PC	
3/8"	160 PSI	11R221PC	
1/2"	160 PSI	11R321PC	12R321PB
3/4"	160 PSI		12R421PB

Material specifications

	11R	12R
Body	Zinc	Zinc
Bottom plug	-	-
Innervalve	-	-
Pilot cap	Zinc	Zinc
Piston & poppet	Plastic	Plastic
Seals	Nitrile	Nitrile
Springs – poppet	Steel	Steel

Most popular.

⚠ WARNING
 Product rupture can cause serious injury.
 Do not connect regulator to bottled gas.
 Do not exceed maximum primary pressure rating.

CAUTION:
REGULATOR PRESSURE ADJUSTMENT –
 The working range of knob adjustment is designed to permit outlet pressures within their full range. Pressure adjustment beyond this range is also possible because the knob is not a limiting device. This is a common characteristic of most industrial regulators, and limiting devices may be obtained only by special design. For best performance, regulated pressure should always be set by increasing the pressure up to the desired setting.



11R

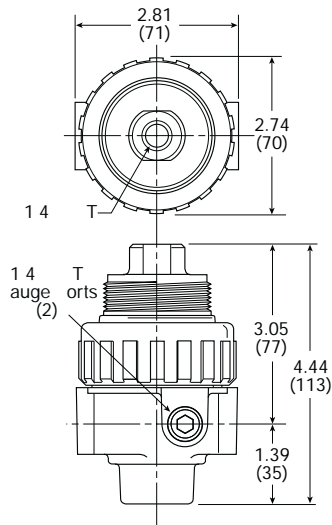

12R

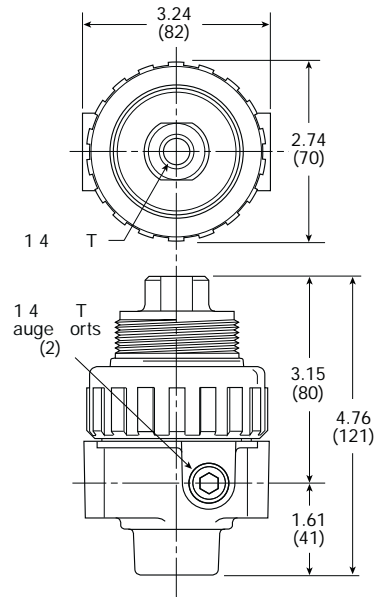

Service kits

		11R	12R
Body service kit		PS713P	PS813P
Gauges –	50mm (2") round 1/4" center back mount	60 PSIG (0 to 4.1 bar) K4520N14060	K4520N14060
		160 PSIG (0 to 11.0 bar) K4520N14160	K4520N14160
		300 PSIG (0 to 20.0 bar) K4520N14300	K4520N14300
	44mm (1-3/4") digital round 1/4" center back mount	0-160 PSIG / 0-11 bar / 0-1.1 MPa K4517N14160	K4517N14160
Mounting bracket kit		PS707P	PS807P
Panel mount nut –	Metal	P04079B	P04079B
	Plastic	P04082	P04082
Pilot conversion kit		PS745P	PS745P
Repair kits –	Non-relieving	PS747P	PS847P
	Relieving	PS749P	PS849P



Air Preparation Products

Global

Prep-Air II

Miniature

P3N

General Industrial

Stainless Steel

Precision / Proportional

Bulk Liquid Separators



Air Preparation Products

Global

Prep-Air II

Miniature

P3N

General Industrial

Stainless Steel

Precision / Proportional

Bulk Liquid Separators

06E Prep-Air II Filter / Regulators

- Space saving package offers both filter and regulator features for optimal performance
- Excellent water removal efficiency
- Rolling diaphragm for extended life
- Quick response, and accurate pressure regulation regardless of changing flow or inlet pressure
- Two high flow 1/4" gauge ports can be used as additional outlets



Material specifications

Adjusting stem		Steel	
Body		Zinc	
Bonnet, internal parts		Plastic	
Bowls	Transparent	Polycarbonate	
	Metal	Zinc	
Bowl guard		Steel	
Collar		Plastic	
Diaphragm		Nitrile	
Drains	Manual twist drain standard	Body & nut	Plastic
		Automatic float drain optional	Float housing
		Seals	Nitrile
		Springs, push rod	Stainless steel
Filter elements		40 Micron (standard)	Plastic
		5 Micron (optional)	Plastic
Knob		Plastic	
Seals		Nitrile	
Sight gauge		Polyamide	
Springs -	Poppet	Stainless	
	Control	Steel	

Operating information

Pressure rating -	
Polycarbonate bowl	0 to 150 PSIG (0 to 10.4 bar)
Metal bowl	0 to 250 PSIG (0 to 17.2 bar)
Automatic float drain	15 to 250 PSIG (1.0 to 17.2 bar)
Temperature rating -	
Polycarbonate bowl	32°F to 125°F (0°C to 52°C)
Metal bowl	32°F to 175°F (0°C to 80°C)
Secondary pressure ranges -	
Standard pressure	2 to 125 PSIG (0 to 8.6 bar)
Medium pressure	1 to 60 PSIG (0 to 4.1 bar)
High pressure	5 to 250 PSIG (0.4 to 17.2 bar)

06E Compact Filter / Regulators

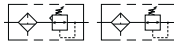

	Port size	Bowl type	Drain type	Flow SCFM	Element type	Part number (NPT)	
						Pressure range (Without gauge)	
						60 PSIG	125 PSIG
06E	1/4"	Poly / Metal guard	Twist	46	40 micron	06E12A11AC	06E12A13AC
	1/4"	Poly / Metal guard	Auto float	46	40 micron	06E16A11AC	06E16A13AC
	3/8"	Poly / Metal guard	Twist	55	40 micron	06E22A11AC	06E22A13AC
	3/8"	Poly / Metal guard	Auto float	55	40 micron	06E26A11AC	06E26A13AC
	1/2"	Poly / Metal guard	Twist	61	40 micron	06E32A11AC	06E32A13AC
	1/2"	Poly / Metal guard	Auto float	61	40 micron	06E36A11AC	06E36A13AC
	1/4"	Metal / Sight gauge	Twist	46	40 micron	06E14A11AC	06E14A13AC
	1/4"	Metal / Sight gauge	Auto float	46	40 micron	06E18A11AC	06E18A13AC
	3/8"	Metal / Sight gauge	Twist	55	40 micron	06E24A11AC	06E24A13AC
	3/8"	Metal / Sight gauge	Auto float	55	40 micron	06E28A11AC	06E28A13AC
	1/2"	Metal / Sight gauge	Twist	61	40 micron	06E34A11AC	06E34A13AC
	1/2"	Metal / Sight gauge	Auto float	61	40 micron	06E38A11AC	06E38A13AC



WARNING

Product rupture can cause serious injury.
 Do not connect regulator to bottled gas.
 Do not exceed maximum primary pressure rating.

CAUTION: REGULATOR PRESSURE ADJUSTMENT -

The working range of knob adjustment is designed to permit outlet pressures within their full range. Pressure adjustment beyond this range is also possible because the knob is not a limiting device. This is a common characteristic of most industrial regulators, and limiting devices may be obtained only by special design. For best performance, regulated pressure should always be set by increasing the pressure up to the desired setting.

Most popular.



06E

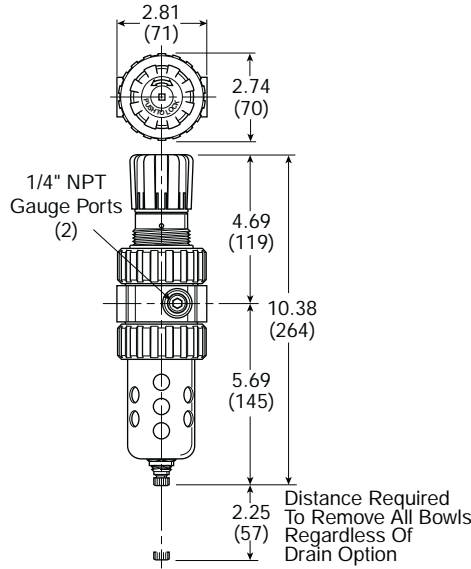

Service kits

Description	06E
Bonnet assembly kit	PS715P
Bowl guard kit	PS705P
Bowl kits	
Poly bowl –	Automatic float drain
	Twist drain
Metal bowl –	Automatic float drain
	Semi-auto drain
	Twist drain
	Sight gauge / Automatic drain
	Sight gauge / Twist drain
Control knob	P04069B
Drain kits –	Automatic float drain
	Semi-auto drain
	Twist drain
	Push 'N' Drain
Filter element kits –	40 Micron
	5 Micron
	Adsorber
Gauges –	60 PSIG (0 to 4.1 bar)
50mm (2") round	160 PSIG (0 to 11.0 bar)
1/4" center back mount	300 PSIG (0 to 20.0 bar)
44mm (1-3/4") digital round	0-160 PSIG / 0-11 bar / 0-1.1 MPa
1/4" center back mount	
Mounting bracket kit (includes panel mount nut)	PS707P
Panel mount nut	P04082
Service kits –	Non-relieving (includes poppet)
	Relieving (includes poppet)
Seat insert kit	PS713P
Springs –	1- 30 PSIG range
	1- 60 PSIG range
	2- 125 PSIG range
	5- 250 PSIG range
Tamperproof kit (key lock)	PS737P

 Most popular.



Air Preparation Products

Global

Prep-Air II

Miniature

P3N

General Industrial

Stainless Steel

Precision / Proportional

Bulk Liquid Separators



Air Preparation Products

Global

Prep-Air II

Miniature

P3N

General Industrial

Stainless Steel

Precision / Proportional

Bulk Liquid Separators

07E Prep-Air II Filter / Regulators

- Space saving package offers both filter and regulator features for optimal performance
- Excellent water removal efficiency
- Rolling diaphragm for extended life
- Quick response, and accurate pressure regulation regardless of changing flow or inlet pressure
- Two high flow 1/4" gauge ports can be used as additional outlets



Material specifications

Adjusting stem		Steel	
Body		Zinc	
Bonnet, internal parts		Plastic	
Bowls	Transparent	Polycarbonate	
	Metal	Zinc	
Bowl guard		Steel	
Collar		Plastic or metal	
Diaphragm		Nitrile	
Drains	Manual twist drain standard	Body & nut	Plastic
		Float housing	Plastic
	Automatic float drain optional	Seals	Nitrile
		Springs, push rod	Stainless steel
Filter elements	40 Micron (standard)	Plastic	
	5 Micron (optional)	Plastic	
Knob		Plastic	
Seals		Nitrile	
Sight gauge		Polyamide	
Springs -	Poppet	Stainless	
	Control	Steel	

Operating information

Pressure rating -	
Polycarbonate bowl	0 to 150 PSIG (0 to 10.4 bar)
Metal bowl	0 to 250 PSIG (0 to 17.2 bar)
Automatic float drain	15 to 250 PSIG (1.0 to 17.2 bar)
Temperature rating -	
Polycarbonate bowl	32°F to 125°F (0°C to 52°C)
Metal bowl	32°F to 175°F (0°C to 80°C)
Secondary pressure ranges -	
Standard pressure	2 to 125 PSIG (0 to 8.6 bar)
Medium pressure	1 to 60 PSIG (0 to 4.1 bar)
High pressure	5 to 250 PSIG (0.4 to 17.2 bar)

07E Standard Filter / Regulators

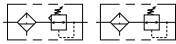

	Port size	Bowl type	Drain type	Flow SCFM	Element type	Part number (NPT)	
						Pressure range (Without gauge)	
						60 PSIG	125 PSIG
	1/2"	Poly / Metal guard	Twist	90	40 micron	07E32A11AC	07E32A13AC
	1/2"	Poly / Metal guard	Auto float	90	40 micron	07E36A11AC	07E36A13AC
	3/4"	Poly / Metal guard	Twist	90	40 micron	07E42A11AC	07E42A13AC
	3/4"	Poly / Metal guard	Auto float	90	40 micron	07E46A11AC	07E46A13AC
	1/2"	Metal / Sight gauge	Twist	90	40 micron	07E34A11AC	07E34A13AC
	1/2"	Metal / Sight gauge	Auto float	90	40 micron	07E38A11AC	07E38A13AC
	3/4"	Metal / Sight gauge	Twist	90	40 micron	07E44A11AC	07E44A13AC
	3/4"	Metal / Sight gauge	Auto float	90	40 micron	07E48A11AC	07E48A13AC

WARNING

Product rupture can cause serious injury.
 Do not connect regulator to bottled gas.
 Do not exceed maximum primary pressure rating.

CAUTION: REGULATOR PRESSURE ADJUSTMENT -

The working range of knob adjustment is designed to permit outlet pressures within their full range. Pressure adjustment beyond this range is also possible because the knob is not a limiting device. This is a common characteristic of most industrial regulators, and limiting devices may be obtained only by special design. For best performance, regulated pressure should always be set by increasing the pressure up to the desired setting.

Most popular.



07E

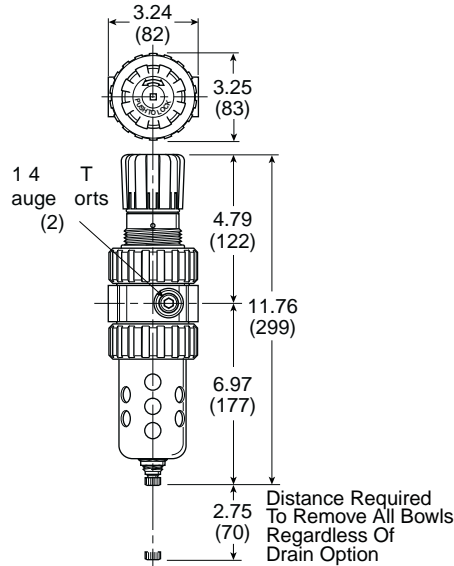

Service kits

Description		07E
Bonnet assembly kit		PS715P
Bowl guard kit		PS805P
Bowl kits – Poly bowl –	Automatic float drain	PS822P
	Twist drain	PS832P
Metal bowl –	Automatic float drain	PS826P
	Semi-auto drain	PS894P
	Twist drain	PS834P
	Sight gauge / Automatic drain	PS823P
	Sight gauge / Twist drain	PS835P
Control knob		P04069B
Drain kits –	Automatic float drain	PS506P
	Semi-auto drain	PS511P
	Twist drain	PS512P
	Push ‘N’ Drain	PS513P
Filter element kits –	40 Micron	PS801P
	5 Micron	PS802P
	Adsorber	PS831P
Gauges –	50mm (2") round 1/4" center back mount	60 PSIG (0 to 4.1 bar) K4520N14060
		160 PSIG (0 to 11.0 bar) K4520N14160
		300 PSIG (0 to 20.0 bar) K4520N14300
44mm (1-3/4") digital round 1/4" center back mount		0-160 PSIG / 0-11 bar / 0-1.1 MPa K4517N14160
Mounting bracket kit (includes panel mount nut)		PS807P
Panel mount nut		P04082
Service kits –	Non-relieving (includes poppet)	PS811P
	Relieving (includes poppet)	PS810P
Seat insert kit		PS813P
Springs –	1- 30 PSIG range	P01698
	1- 60 PSIG range	P04062
	2- 125 PSIG range	P04063
	5- 250 PSIG range	P04064
Tamperproof kit (key lock)		PS737P

 Most popular.



Air Preparation Products

Global

Prep-Air II

Miniature

P3N

General Industrial

Stainless Steel

Precision / Proportional

Bulk Liquid Separators



16L, 17L Prep-Air II Micro-Mist Lubricators

- Proportional oil delivery over a wide range of air flows
- Generates oil particles of 5 micron or smaller downstream to lubricate systems having complex piping arrangements
- Precision needle valve assures repeatable oil delivery and provides simple adjustment of delivery rate
- Ideal for low and high flow applications with changing air flow
- Transparent sight dome for 360° visibility
- Yellow fill cap identifies Micro-Mist Lubricator
- 16L: 1/4", 3/8" & 1/2" ports (NPT & BSPP)
- 17L: 1/2" & 3/4" ports (NPT & BSPP)

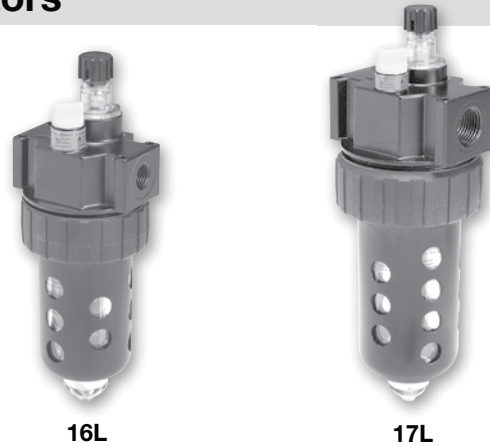

Material specifications

Body	Zinc
Bowls –	
Transparent	Polycarbonate
Metal	Zinc
Bowl guards	Steel
Collar	Plastic (16, 17) or metal (17)
Drains, twist / body & nut	Plastic
Injector meter block & base assembly	Plastic
Seals	Nitrile
Sight dome	Polycarbonate
Sight gauge	Polyamide (Nylon)

Operating information

Pressure rating –
 Polycarbonate bowl 0 to 150 PSIG (0 to 10.4 bar)
 Metal bowl 0 to 250 PSIG (0 to 17.2 bar)



Temperature rating –
 Polycarbonate bowl 32°F to 125°F (0°C to 52°C)
 Metal bowl 32°F to 175°F (0°C to 80°C)

Minimum flow for lubrication: 1 SCFM at 100 PSIG

Suggested lubricant: F442 oil
 Petroleum based oil of 100 to 200 SSU viscosity at 100°F (38°C) and an aniline point greater than 200°F (93°C)
 (DO NOT USE OILS WITH ADDITIVES, COMPOUNDED OILS CONTAINING SOLVENTS, GRAPHITE, DETERGENTS, OR SYNTHETIC OILS.)

Compact & Standard Lubricators



	Port size	Bowl type	Flow SCFM	Part number (NPT)	
				Twist drain	No drain
16L 	1/4"	Poly / Metal guard	40		16L12BE
	1/4"	Metal / Sight gauge	40	16L14BE	
	3/8"	Poly / Metal guard	60		16L22BE
	3/8"	Metal / Sight gauge	60	16L24BE	
	1/2"	Poly / Metal guard	90		16L32BE
17L 	1/2"	Poly / Metal guard	90		17L32BE
	1/2"	Metal / Sight gauge	90	17L34BE	
	3/4"	Poly / Metal guard	90		17L42BE
	3/4"	Metal / Sight gauge	90	17L44BE	

16L

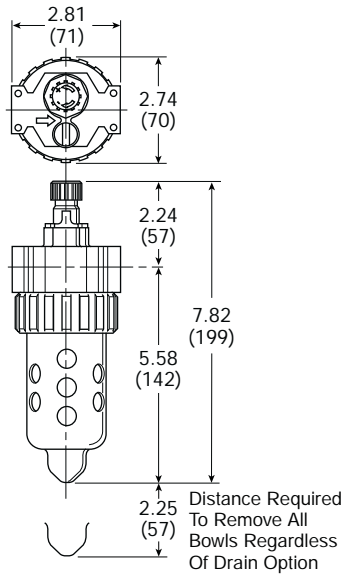

17L

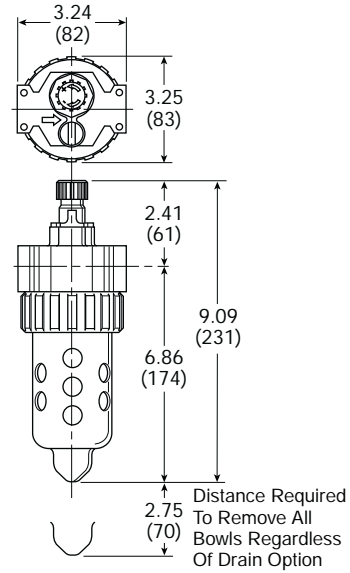

Service kits

Description		16L (Compact)	17L (Standard)
Adjustment knob		P04121	P04121
Bowl guard kit		PS705P	PS805P
Bowl Kits:	Poly bowl – No drain	PS746P	PS846P
	Twist drain	PS717P	PS817P
	Pressure fill	PS719P	PS819P
	Remote fill	PS728P	PS828P
	Metal bowl – Sight gauge / Twist drain	PS729P	PS829P
	Sight gauge / Pressure fill	PS720P	PS820P
Drain kit	Twist drain	PS512P	PS512P
Fill cap kit		PS742P	PS742P
Lubricator service kit		PS748P	PS748P
Mounting bracket kit		PS743P	PS843P
Oil –	1 Gal	F442002	F442002
	12 Quart case	F442003	F442003
	4 Gal case	F442005	F442005
Pressure fill adapter kit		PS716P	PS716P
Pressure fill button		P11912	P11912
Remote auto-fill device		PS505CP	PS505CP
Sight dome / Fill cap kit		PS739P	PS739P
Sight dome kit		PS740P	PS740P
Nylon sight dome kit		PS740N	PS740N



Air Preparation Products

Global

Prep-Air II

Miniature

P3N

General Industrial

Stainless Steel

Precision / Proportional

Bulk Liquid Separators

06L, 07L Prep-Air II Mist Lubricators

- Proportional oil delivery over a wide range of air flows
- Precision needle valve assures repeatable oil delivery and provides simple adjustment of delivery rate
- Bowl can be filled while air line is under pressure
- Transparent sight dome for 360° visibility
- 06L: 1/4", 3/8" & 1/2" ports (NPT & BSPP)
- 07L: 1/2" & 3/4" ports (NPT & BSPP)



06L



07L

Material specifications

Body	Zinc
Bowls –	
Transparent	Polycarbonate
Metal	Zinc
Bowl guards	Steel
Collar	Plastic (06, 07) or metal (07)
Drain	Plastic
Injector meter block & base assembly	Plastic
Seals	Nitrile
Sight dome	Polycarbonate
Sight gauge	Polyamide (Nylon)

Operating information

Pressure rating –
 Polycarbonate bowl 0 to 150 PSIG (0 to 10.4 bar)
 Metal bowl 0 to 250 PSIG (0 to 17.2 bar)



Temperature rating –
 Polycarbonate bowl 32°F to 125°F (0°C to 52°C)
 Metal bowl 32°F to 175°F (0°C to 80°C)

Minimum flow for lubrication: .5 SCFM at 100 PSIG

Suggested lubricant: F442 oil
 Petroleum based oil of 100 to 200 SSU viscosity at 100°F (38°C)
 and an aniline point greater than 200°F (93°C)
 (DO NOT USE OILS WITH ADDITIVES, COMPOUNDED OILS
 CONTAINING SOLVENTS, GRAPHITE, DETERGENTS, OR
 SYNTHETIC OILS.)

Compact & Standard Lubricators



	Port size	Bowl type	Flow SCFM	Part number (NPT)	
				Twist drain	No drain
06L 	1/4"	Poly / Metal guard	40		06L12BE
	1/4"	Metal / Sight gauge	40	06L14BE	
	3/8"	Poly / Metal guard	60		06L22BE
	3/8"	Metal / Sight gauge	60	06L24BE	
	1/2"	Poly / Metal guard	90		06L32BE
07L 	1/2"	Metal / Sight gauge	90	06L34BE	
	1/2"	Poly / Metal guard	90		07L32BE
	3/4"	Poly / Metal guard	90		07L42BE
	3/4"	Metal / Sight gauge	90	07L44BE	

06L

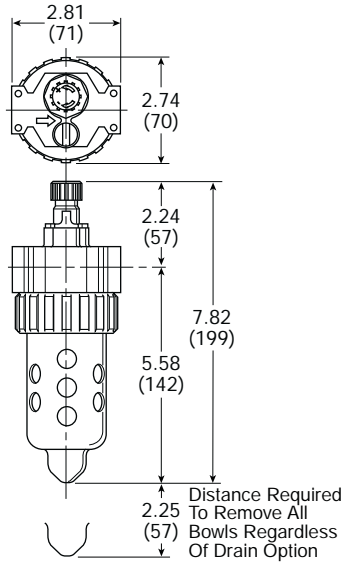

07L

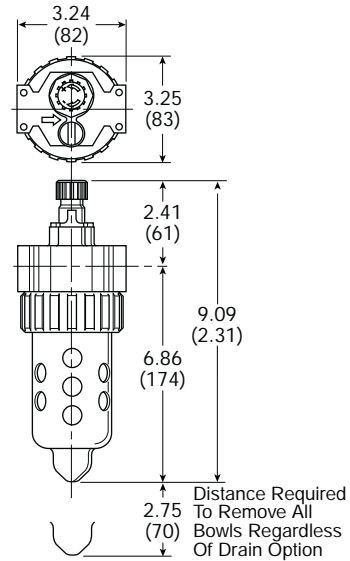

Service kits

Description	06L (Compact)	07L (Standard)
Adjustment knob	P04121	P04121
Bowl guard kit	PS705P	PS805P
Bowl Kits – Poly bowl –	No drain	PS746P
	Twist drain	PS717P
	Pressure fill	PS719P
	Remote fill	PS728P
Metal bowl –	Sight gauge / Twist drain	PS729P
	Sight gauge / Pressure fill	PS720P
Drain kit	Twist drain	PS512P
Fill cap kit	PS741P	PS741P
Lubricator service kit	PS718P	PS718P
Mounting bracket kit	PS743P	PS843P
Oil –	1 Gal	F442002
	12 Quart case	F442003
	4 Gal case	F442005
Pressure fill adapter kit	PS716P	PS716P
Pressure fill button	P11912	P11912
Remote auto-fill device	PS505CP	PS505CP
Sight dome / fill cap kit	PS738P	PS738P
Sight dome kit	PS740P	PS740P
Nylon sight dome kit	PS740N	PS740N



Air Preparation Products

Global

Prep-Air II

Miniature

P3N

General Industrial

Stainless Steel

Precision / Proportional

Bulk Liquid Separators

Compact & Standard Prep-Air II Combinations

Close Nippled Combinations – 06 Compact & 07 Standard Series

- Regulator can be mounted with knob in up or down position
- 40 micron filter element standard, 5 micron optional
- Manual twist drain
- Relieving regulator

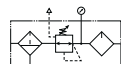
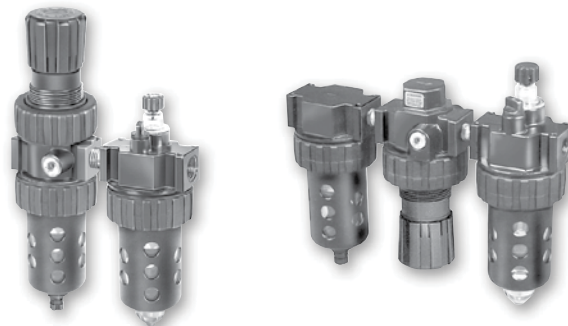

06G, 16G, 07G, 17G 2-Unit Close Nippled Combinations

	Port	Bowl type	Element type	Filter drain type	Relief type	Lubricator drain type	Series	Model numbers	Series	Model numbers
06G Shown	1/4"	Poly / Metal guard	40 micron	Twist	Relieving	None	06G	06G12A13A2BC	16G	16G12A13A2BC
	3/8"	Poly / Metal guard	40 micron	Twist	Relieving	None		06G22A13A2BC		16G22A13A2BC
	1/2"	Poly / Metal guard	40 micron	Twist	Relieving	None		06G32A13A2BC		16G32A13A2BC
	1/2"	Poly / Metal guard	40 micron	Twist	Relieving	None	07G	07G32A13A2BD	17G	17G32A13A2BD
	3/4"	Poly / Metal guard	40 micron	Twist	Relieving	None		07G42A13A2BD		17G42A13A2BD



06A, 16A, 07A, 17A 3-Unit Close Nippled Combinations

	Port	Bowl type	Element type	Filter drain type	Relief type	Lubricator drain type	Series	Model numbers	Series	Model numbers
06A Shown	1/4"	Poly / Metal guard	40 micron	Twist	Relieving	None	06A	06A12A13A2BC	16A	16A12A13A2BC
	3/8"	Poly / Metal guard	40 micron	Twist	Relieving	None		06A22A13A2BC		16A22A13A2BC
	1/2"	Poly / Metal guard	40 micron	Twist	Relieving	None		06A32A13A2BC		16A32A13A2BC
	1/2"	Poly / Metal guard	40 micron	Twist	Relieving	None	07A	07A32A13A2BD	17A	17A32A13A2BD
	3/4"	Poly / Metal guard	40 micron	Twist	Relieving	None		07A42A13A2BD		17A42A13A2BD

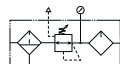

WARNING

Product rupture can cause serious injury.
 Do not connect regulator to bottled gas.
 Do not exceed maximum primary pressure rating.

CAUTION: REGULATOR PRESSURE ADJUSTMENT –

The working range of knob adjustment is designed to permit outlet pressures within their full range. Pressure adjustment beyond this range is also possible because the knob is not a limiting device. This is a common characteristic of most industrial regulators, and limiting devices may be obtained only by special design. For best performance, regulated pressure should always be set by increasing the pressure up to the desired setting.

Most popular.

Compact & Standard Prep-Air II Combinations

Modular Combinations – 06 Compact & 07 Standard Series

- Regulator can be mounted with knob in up or down position
- 40 micron filter element standard, 5 micron optional
- Manual twist drain
- Relieving regulator

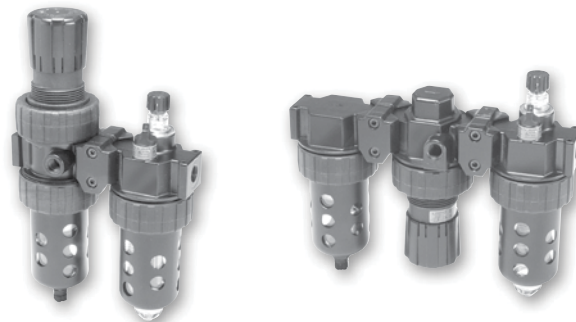

CAUTION:
REGULATOR PRESSURE ADJUSTMENT –

The working range of knob adjustment is designed to permit outlet pressures within their full range. Pressure adjustment beyond this range is also possible because the knob is not a limiting device. This is a common characteristic of most industrial regulators, and limiting devices may be obtained only by special design. For best performance, regulated pressure should always be set by increasing the pressure up to the desired setting.

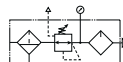

06H, 16H, 07H, 17H 2-Unit Modular Combinations

	Port	Bowl type	Element type	Filter drain type	Relief type	Lubricator drain type	Series	Model numbers	Series	Model numbers
06H Shown 	1/4"	Poly / Metal guard	40 micron	Twist	Relieving	None		06H12A13A2BC		16H12A13A2BC
	3/8"	Poly / Metal guard	40 micron	Twist	Relieving	None	06H	06H22A13A2BC	16H	16H22A13A2BC
	1/2" *	Poly / Metal guard	40 micron	Twist	Relieving	None		06H32A13A2BCG		16H32A13A2BCG
	1/2"	Poly / Metal guard	40 micron	Twist	Relieving	None	07H	07H32A13A2BD	17H	17H32A13A2BD
	3/4"	Poly / Metal guard	40 micron	Twist	Relieving	None		07H42A13A2BD		17H42A13A2BD

* 06 / 16 Available with port blocks only.

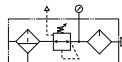

06B, 16B, 07B, 17B 3-Unit Modular Combinations

	Port	Bowl type	Element type	Filter drain type	Relief type	Lubricator drain type	Series	Model numbers	Series	Model numbers
06B Shown 	1/4"	Poly / Metal guard	40 micron	Twist	Relieving	None		06B12A13A2BC		16B12A13A2BC
	3/8"	Poly / Metal guard	40 micron	Twist	Relieving	None	06B	06B22A13A2BC	16B	16B22A13A2BC
	1/2" *	Poly / Metal guard	40 micron	Twist	Relieving	None		06B32A13A2BCG		16B32A13A2BCG
	1/2"	Poly / Metal guard	40 micron	Twist	Relieving	None	07B	07B32A13A2BD	17B	17B32A13A2BD
	3/4"	Poly / Metal guard	40 micron	Twist	Relieving	None		07B42A13A2BD		17B42A13A2BD

* 06 / 16 available with port blocks only.

Modular service kits

Description	06 Series	07 Series	Description	Series	Size	NPT	BSPP	BSPT
Body connectors	PS754P	PS854P	Port block connector kits	06 Series –	1/4"	PS750P	PS765P†	PS761P
Lockout valves	PS756P	PS856P			3/8"	PS751P	PS766P†	PS762P
Modular manifold block	PS757P	PS857P			1/2"	PS752P*	PS767P**	PS799P*
Wall mounting kit	PS755P	PS755P	07 Series –	07 Series –	1/4"	PS850P	PS865P	PS861P
					3/8"	PS851P	PS866P	PS862P
					1/2"	PS852P	PS867P†	PS863P
					3/4"	PS853P	PS860P	PS864P

⚠ WARNING
 Product rupture can cause serious injury.
 Do not connect regulator to bottled gas.
 Do not exceed maximum primary pressure rating.

Use 1/4 or 3/8 ported bodies. † 1/4, 3/8 & 1/2 inch meet ISO 1179-1 Standard. ‡ 1/2 inch meets ISO 1179-1 Standard.

 Most popular.

Combination Dimensions – 06 Compact & 07 Standard Series

Air Preparation Products

Global

Prep-Air II

Miniature

P3N

General Industrial

Stainless Steel

Precision / Proportional Bulk Liquid Separators

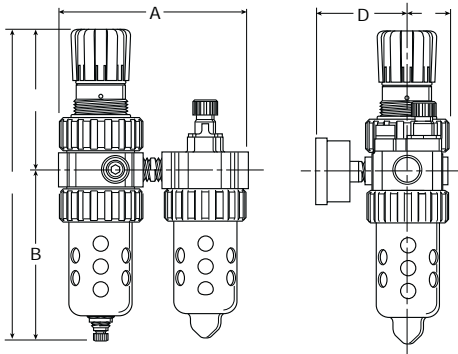

06G, 16G Series

A	B	C	D	E	F
6.13 (156)	5.69 (145)	4.69 (119)	3.18 (81)	10.38 (264)	1.37 (35)

07G, 17G Series

A	B	C	D	E	F
6.99 (178)	6.97 (177)	4.79 (122)	3.44 (87)	11.76 (299)	1.63 (41)

Inches (mm)

• All dimensions nominal.

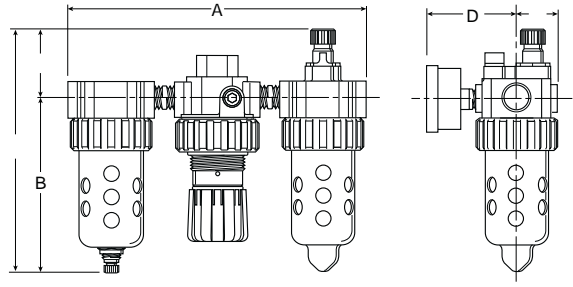

06A, 16A Series

A	B	C	D	E	F
9.45 (240)	5.69 (145)	2.24 (57)	3.18 (81)	7.93 (201)	1.37 (35)

07A, 17A Series

A	B	C	D	E	F
10.74 (2738)	6.97 (177)	2.41 (61)	3.44 (87)	9.38 (238)	1.63 (41)

Inches (mm)

• All dimensions nominal.

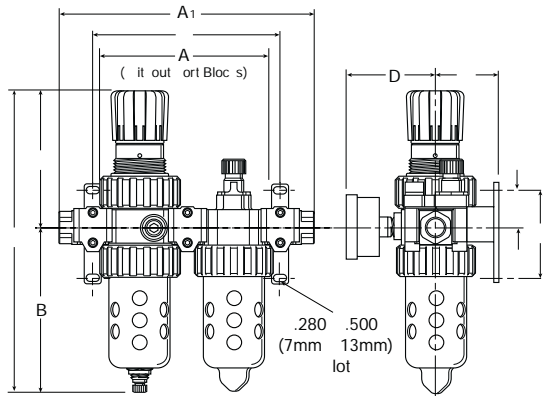

06H, 16H Series

A	A1	B	C	D	E
6.10 (155)	9.04 (230)	5.69 (145)	4.69 (119)	3.18 (81)	10.38 (264)

F	G	H	J
2.00 (51)	3.58 (91)	1.40 (36)	6.65 (169)

07H, 17H Series

A	A1	B	C	D	E
7.00 (178)	10.28 (261)	6.97 (177)	4.79 (122)	3.44 (87)	11.76 (299)

F	G	H	J
2.09 (53)	3.58 (91)	1.40 (36)	7.51 (191)

Inches (mm)

• All dimensions nominal.

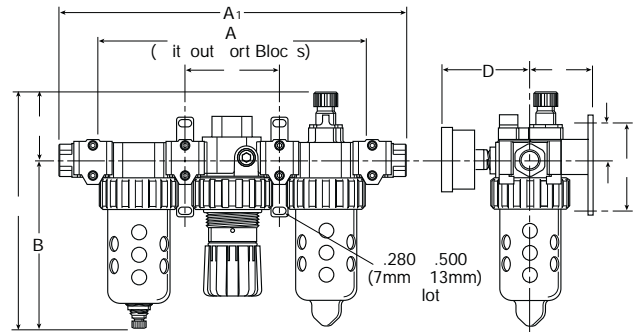

06B, 16B Series

A	A1	B	C	D	E
9.46 (240)	12.39 (315)	5.69 (145)	2.24 (57)	3.18 (81)	7.93 (202)

F	G	H	J
2.00 (51)	3.58 (91)	1.40 (36)	3.33 (85)

07B, 17B Series

A	A1	B	C	D	E
10.75 (273)	14.03 (356)	6.97 (177)	2.41 (61)	3.44 (87)	9.38 (238)

F	G	H	J
2.18 (55)	3.58 (91)	1.40 (36)	3.76 (95)

Inches (mm)

• All dimensions nominal.

